



AC/DC- Converter / Battery charger

Series PSI

1200Watt

Type	Output adjustable			Boost charge	Alarm
	Spannung (VDC)	Strom (ADC)	OVP (VDC)	max. (VDC)	U _{OUT} (≤VDC)
PSI 1200/24	23 - 28	30 - 40	24 - 33	29	20
PSI 1200/36	34 - 42	20 - 25	36 - 50	43	30
PSI 1200/48	46 - 56	15 - 20	48 - 65	58	41
PSI 1200/60	58 - 70	12 - 16	60 - 80	72	51
PSI 1200/110	100 - 130	7 - 9	110 - 150	132	95
PSI 1200/220	200 - 260	3 - 4,5	220 - 300	264	190

Technical Data Series PSI

Input

Voltage a) 185-264 VAC 45-65 Hz
b) 260-370VDC no NTC
EMV HF-Spikes/Burst EN60801-3/4/5-level III
Inrush current NTC 7 Ω, 10A
Switch on time 7s typical
Power factor 0.75 cap. typical, Crest 2.5
No load current typical 0,25A 1
Current nom. load 9A at 185V
Hold up time 20ms / 230V
RFI EN55022-"A"
Fuse external Fuse
10A slow blow or
16A Circuit Breaker "C" or "K"

Output

decoupling by diode,
no load protected, OCP and OVP
see table
Voltage see table
Current see table
Output characteristic UI / Option W,Z,T
0Voltage regulation stat. +-2% or +-1V which ever is
greater dyn. +-4% 10 - 100% Load
Sense lines 10% UOUT max. compensating
Current regulation +-5% / nominal load
Ripple <200mV P/P
<2mV psophometrie CISPR
Recovery time 1ms typ.
OVP (Over voltage protec.) see table
electronic turn -off <2ms
reset through push-button
OTP (Over temperature) turn off - Reset through
push button
Redundant operation possible through built in diode
Parallel operation possible, unlimited
Operation in series possible with option U
(cross diode)
Boost charge Option W = manual switch
Option Z = manual switch
with automatic, time delayed return
see table
Option T Temp. compensated charging

Controls/ Indicators

Control elements / Indicators
(on Front panel) LED 1 green/Power On
LED 2 red/over voltage
LED 3 red/over temperature
reset-push button for 2, 3
potentiometer U OUT
potentiometer OVP
External Alarm
(on Connector) anode decoupling diode
max. 0,1A
output <85% Unom by
potentialfree contacts
1 NCC / 1 NOC
250V / 1A / 40W max.
Values see table

General

Operation temperature 0°C to +60°C
Load derating 2,5% / °C from +40°C
Storage temperature -20°C to +70°C
Humidity 75% without condensation
Cooling regulated DC-fans
intake through front panel
exhaust through rear panel
Switching frequency app. 80 kHz
Construction VDE 0804 / EN 60950
class 1
Isolation input/all/3500 VDC
output/all/1400 VDC
Creepage distance 6mm input / output
4mm case / all
Air distance 6mm input / output
4mm case/ all
Mechanical construction designed for 19"-racks 3U,
335mm deep
Front plate 42TE / RAL 7032
Connector 2 x H15, DIN 41612
Weight app. 5kg
EMV EN 61000-6-2 / EN 61000-6-4

General Description

Primary Circuit

The input is connected to the primary switching system via NTC, RFI filter 2 and bridge-connected rectifier 3. The filter reduces switching noise that is conducted into the primary supply system. NTC resistor 1 limits the inrush current. The rectified input voltage can be used for connection of additional storage capacitors or DC- supply voltage of 260 - 370VDC.

The switching system is a push-pull circuit in full-bridge connection. Switching transistors 6a and 6b are controlled by circuit 8 alternately conducting with variable pulse-width, connecting the rectified input voltage with alternating polarity to the primary winding of transformer 5. The signal across C.T. 7 is used for current limiting for the protection of the semiconductors against excessive current.

Secondary Circuit

The voltage of the primary windings is transformed to the secondary side in the turns ratio of the windings, is then rectified by diodes 11a and 11b and filtered by choke 12 in conjunction with capacitor 14. The average value of the voltage across the capacitor depends on the input voltage and the on/off-ratio of the switching transistors. It is conducted to the output terminals ripple filter 16.

The output voltage is connected via external sense leads to the voltage control circuit 18. There it is compared with a reference, and the error signal controls, via an optocoupler, the switching transistor at the primary side. For overvoltage protection (OVP) circuit 17 senses internally the output voltage and turns off the switching transistors via an optocoupler, if a certain adjustable level is reached. Reset by pressing frontpanel push button switch.

For current limiting the signal across C.T. 13 starts to reduce the output voltage if the current exceeds a certain limit. For the reason of dynamic stability this circuit responds with some delay, whereas the primary limiting circuit interfaces nearly instantaneously for fast protection of the semiconductors. Cooling is assured by internal DC-fan 22. Overtemperature protection is made by circuit 21, which turns off the switching transistors. Reset by pressing frontpanel push button switch.

Decoupling diode 19 prevents reverse current during charging or redundant operations. Anode is available for control purposes. Circuit 20 senses output for low voltage. Alarm is given by potential

Block Diagram

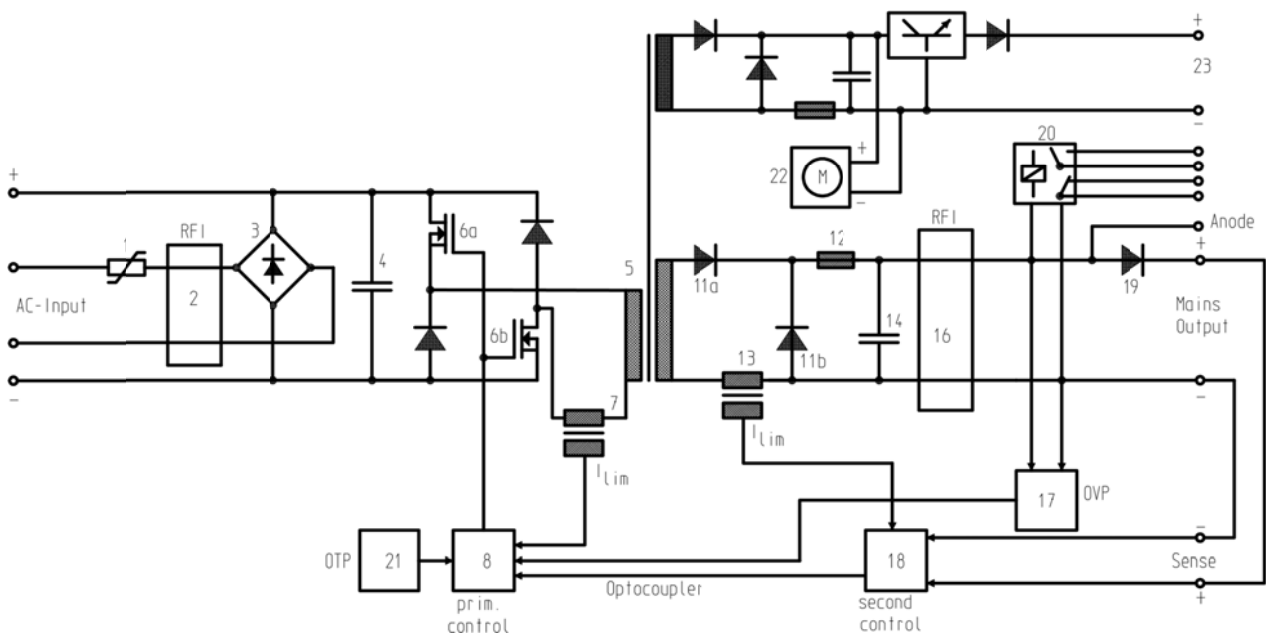

General Information

Starting Behaviour

When the module is connected to the input power, the primary capacitors will be charged by a high current pulse. The magnitude of this pulse mainly depends on the supply system. With an internal thermistor in series with the input, this current pulse is reduced. This current limiting will not be effective if the power is interrupted for a short period of time only, not allowing the thermistor to cool down. The build-up of the output voltage is electronically delayed by a soft-start circuit on the control board and does not contribute to the current surge at the input during turn-on. The output voltage reaches the final value in approx. 2s after the application of input power.

No Load Operation

The primary and the secondary control circuits are powered from auxiliary windings on the main transformer, and in order to keep them in operation, the oscillation must be maintained, even with no output load. Since a certain amount of energy is transferred to the secondary side with every cycle, a small base load is built into the module in the order of 1...2% of the rated load. No additional external load is required for stable operation.

Overvoltage Protection (OVP)

To protect the load and the internal circuits against excessive output voltage, an independent circuit switches off the primary control pulses if a certain adjustable output voltage is exceeded, so that no more energy is transmitted to the secondary side. Different from „crow-bar“ circuits, which apply a short circuit across the output terminals by firing a thyristor, the system used here does not provide protection against overvoltage that comes from outside which, however, is quite unlikely to happen. After pressing the reset button the unit returns back to operation.

Overtemperature Protection (OTP)

To protect the unit against over temperature in case of fan failure, blocked filter pad or ext. over temperature an independent circuit switches off the output voltage within 2ms. After cooling down press the reset button to get the converter back in function.

Output Ripple

The output voltage of switch mode converters/power supplies is generated by a filter circuit from PWM regulated AC voltage. According to the modes of filtering used, a ripple remains more or less. This ripple consists of periodic changes of the output voltage and also of the spikes generated by transistors and diodes turning on/off. It is defined and measured at the maximum input voltage / maximum output current up to 30 MHz bandwidth.

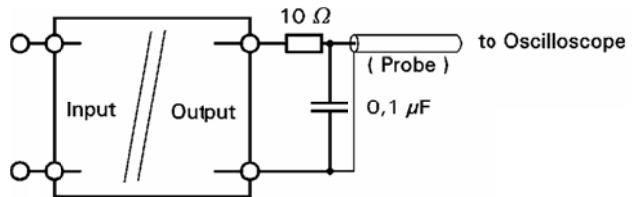

A test set-up must have the shortest possible connections to avoid or minimize pick-up and measuring faults. A small filter set-up will help (see drawing).

Even at short connections between the power supply and load, ripple and spikes may increase due to high switching currents combined with capacities / inductances of wiring / PCB's. Small capacitor blocks (1μF electrolytic / 0.1μF MKT) connected as near as possible to the load will solve this problem in most cases.

Current Limiting

To protect the module and the load against excessive current, a circuitry is provided that senses the output current and takes over control when a certain level is exceeded. The current limit operates as a constant current source with approx. 5% accuracy. This allows the charging of all kinds of batteries.

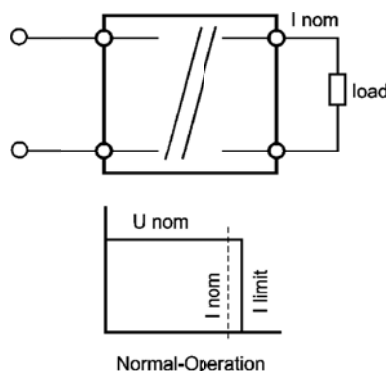

Serial Connection for Higher Voltage

This mode of operation can be used without any problems, but the following points should be considered:

1. The output ripple of the individual units may add up to a higher absolute value (relatively it remains the same).
2. The total output voltage should not exceed the safety / isolation limits of the individual units.
3. Should one unit fail, its output will then be loaded by the other units with wrong polarity. Therefore, all the outputs should be protected by a cross diode.

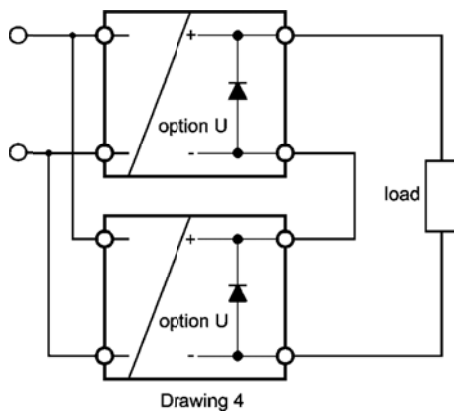

Parallel Connection for Higher Power

In order to increase the output power/current, as many identical units as possible can be parallel connected. However, the following should be taken into consideration:

1. The output voltages should be adjusted as close as possible to each other in order to minimize the voltage tolerance. This adjustment should then be made when the outputs are loaded 10 - 20% nominal.
2. It is absolutely necessary to set the current limit to $\leq 100\%$ nominal.
3. The output wires must be connected to one point.

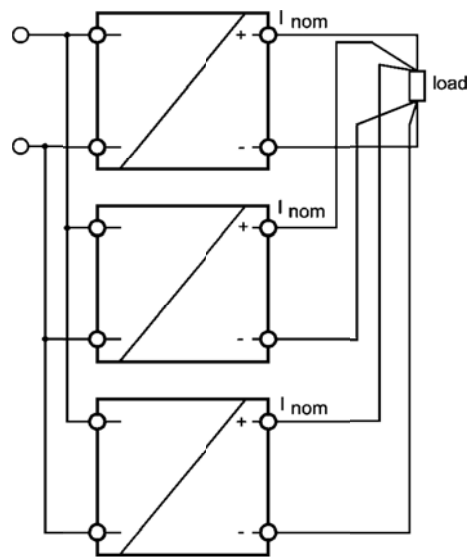

Dimensions / Adjustments

Front view

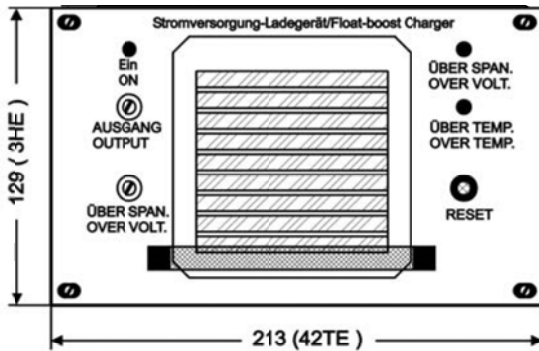

LED ON /Green LED indicates presence of DC output

SET OUTPUT
The output voltage can be set by this multiturn potentiometer

SET OVER VOLT
The over-voltage setting can be altered by this multiturn potentiometer.

LED OVER VOLT
Red LED indicates that the output voltage was above the limit set by over-voltage potentiometer. The output voltage is reduced to zero in this condition.

Rear view

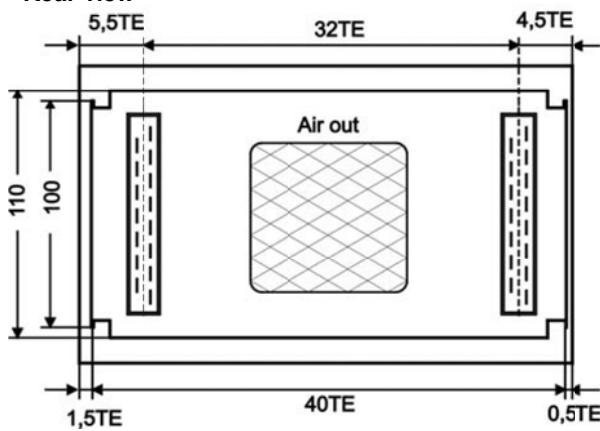

LED OVER TEMP
Red LED indicates excessive temperature of heat sinks inside. The output is shut off in this condition. Cooling time is about 20min.

RESET-Button
This push-button resets the alarm condition as soon as it is pressed and released. Unit will try to restart. If the alarm condition persists unit will trip again. Don't press during operation of the unit, because during restart the output is off for a short time.

Set Current Limit
The output current limit can be set by this single turn potentiometer on the top of the unit.

Top view

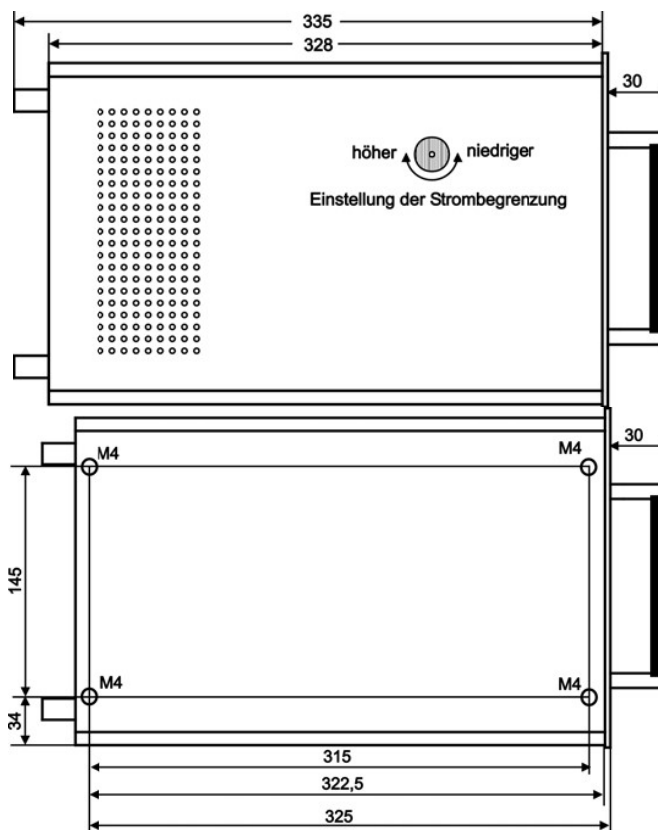

All dimensions in mm
1TE = 1U = 5,08mm
1HE = 1U = 44,45mm

Bottom view

Internal electrical options

T Temperature controlled output voltage

By using an additional external resistor, NTC or PTC connected to a sense line of the unit, the output voltage can be programmed. e. g. for temperature controlled charging of batteries.

WA / ZA

Boost charge

With actuation of an external switch the output voltage becomes higher especially for boost charge. The system comes back in float operation manually or automatically by a time relay (ZA).

WP / ZP

Battery check

With actuation of an external switch the output voltage is programmed down example to $1,90^{V}_{cell}$. Therefore the load is supplied by the Battery. The system comes back in float operation manually or automatically by a time relay (ZP).

External electrical options, additional mechanic options necessary

A Drop down diodes

Through external diodes the output voltage is programmed to the specified load voltage. With battery discharging the diodes are automatically by- passed.

CE Additional input capacitors

To extend the carry-over-time at mains fail.

CA Additional output capacitors

To extend the carry-over-time or for releasing fuse elements

P Battery monitoring and total discharge protection

An additional circuit is monitoring the battery voltage in case of mains fail. Typical at 80% of the nom. battery voltage, a deep discharge protection relay interrupt the connection to the load.

SE/SA Circuit breaker at the input and / or output

E Earth leakage protection module

J Main switch

Y Measuring instruments (V, A etc.)

Configurations

19"- racks BGT- series

aluminum racks with conductive chromates surfaces. Incl. installed unit guiding and already connected mating plugs. Unused plug in slots or empty space on the front is covered by aluminum "blind-" plates.

Order no.: **BGT 231-...**

For 1 x PSI 1200, electrical options please s. page 6.
Ready- for- use the connectors are wired to terminals on the rear side.

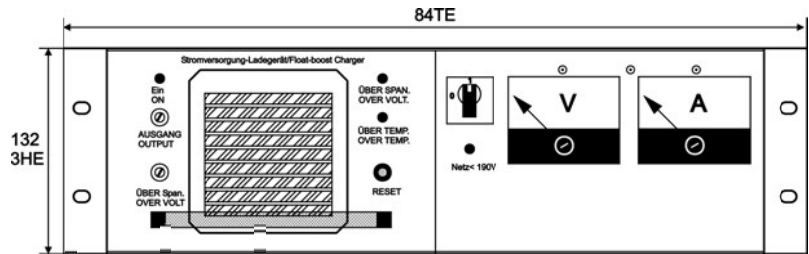

Depth: 380mm

Order no.: **BGT 232-...**

For 2 x PSI 1200, electrical options upon request, please s. page 6 Ready- for- use the connectors are wired to terminals on the rear side.

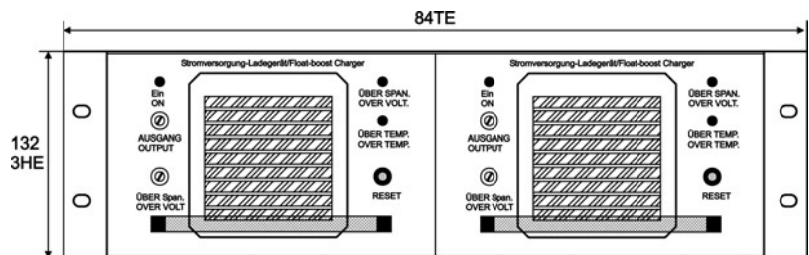

Depth: 380mm up to 470mm (depends on options)

Order no.: **BGT 252-...**

For 2 x PSI 1200, electrical options please s. page 6.
Ready- for- use the connectors are wired to terminals on the rear side.

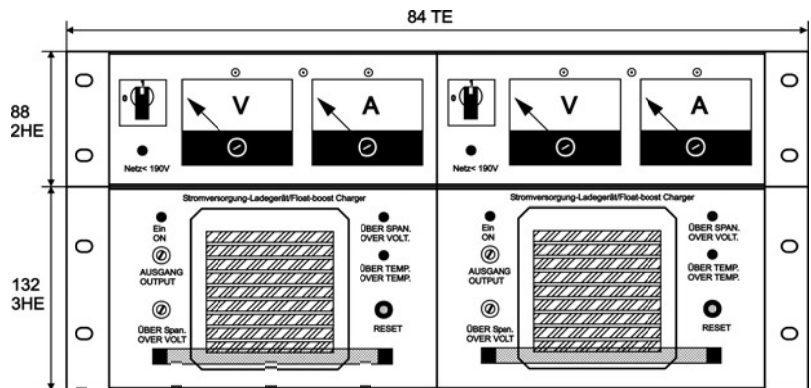

Depth: 380mm up to 470mm (depends on options)

Order no.: **BGT 263-...**

For 3 x PSI 1200, electrical options please s. page 6.
Ready- for- use the connectors are wired to terminals on the rear side.

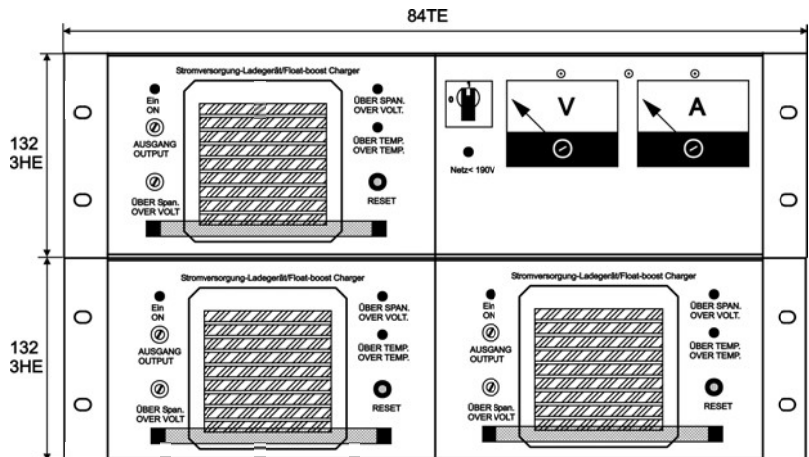

Depth: 380mm up to 470mm (depends on options)

Mounting plate / Option - M

series PSI 1200 mounted on a wall mounting plate. The converter is fixed by 4 x M5 screws; the mechanical realisation is made in protection class IP00.

Order no.: **PSI 1200-M10** (connection on terminals, optional with int. Fuse)

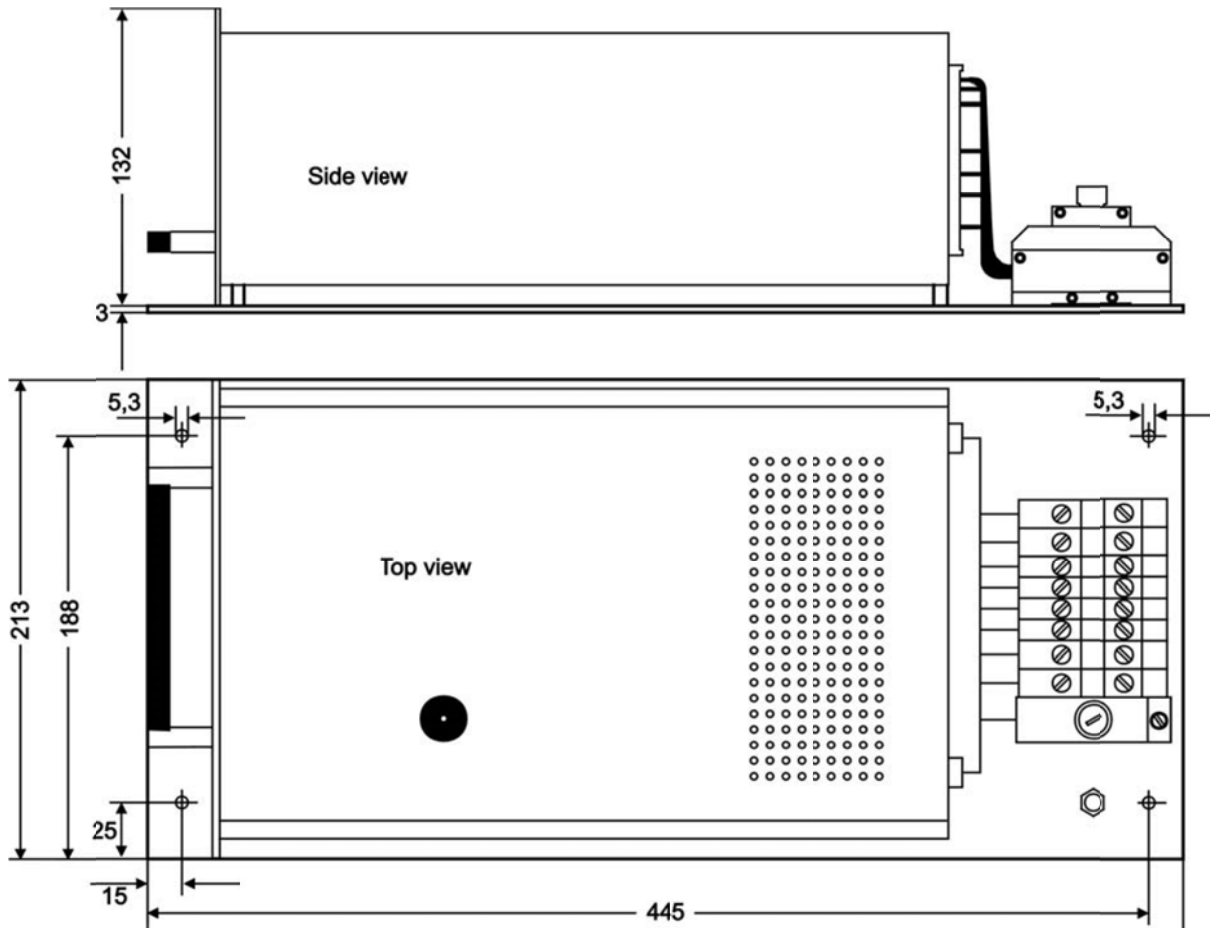

all dim. in mm
 1TE = 1U = 5,08mm
 1HE = 1U = 44,45mm

Projects



Train application for stationary battery charging at 16²/₃ Hz

BGT 252 in cabinet

Units: 2 x PSI 1200/36
(2 x 40,5VDC/2 x 25A)

Options:

- 2 x N Mains fail alarm
- 2 x CE 16²/₃ Hz-operation
- 2 x J Main switch
- 2 x Y Dig. measuring V+A

Redundant 24VDC- supply

BGT 232

Units: 2 x PSI 1200/24
(2 x 24VDC/2 x 40A)

Options:

- CA additional output cap. to Extend carry-over-time
- 2 x SSE Circuit breaker at the input with auxiliary contacts
- 4 x SSA Circuit breaker at the output with auxiliary contacts
- 2 x N Mains fail alarm

